

BXUV.P922 - FIRE-RESISTANCE RATINGS - ANSI/UL 263

Design/System/Construction/Assembly Usage Disclaimer

- Authorities Having Jurisdiction should be consulted in all cases as to the particular requirements covering the installation and use of UL Certified products, equipment, system, devices, and materials.
- Authorities Having Jurisdiction should be consulted before construction.
- Fire resistance assemblies and products are developed by the design submitter and have been investigated by UL for compliance with applicable requirements. The published information cannot always address every construction nuance encountered in the field.
- When field issues arise, it is recommended the first contact for assistance be the technical service staff provided by the product manufacturer noted for the design. Users of fire resistance assemblies are advised to consult the general Guide Information for each product category and each group of assemblies. The Guide Information includes specifics concerning alternate materials and alternate methods of construction.
- Only products which bear UL's Mark are considered Certified.

BXUV - Fire Resistance Ratings - ANSI/UL 263 Certified for United States

BXUV7 - Fire Resistance Ratings - CAN/ULC-S101 Certified for Canada

See General Information for Fire-resistance Ratings - ANSI/UL 263 Certified for United States Design Criteria and Allowable Variances

See General Information for Fire Resistance Ratings - CAN/ULC-S101 Certified for Canada Design Criteria and Allowable Variances

Design No. P922

February 11, 2019

Restrained Assembly Rating — 1, 1-1/2 or 2 Hr (See Items 6, 7)

Unrestrained Assembly Rating — 0 Hr (See Item 6)

Unrestrained Beam Rating — 1, 1-1/2 or 2 Hr (See Item 7)

This design was evaluated using a load design method other than the Limit States Design Method (e.g., Working Stress Design Method). For jurisdictions employing the Limit States Design Method, such as Canada, a load restriction factor shall be used — See Guide BXUV or BXUV7

*** Indicates such products shall bear the UL or cUL Certification Mark for jurisdictions employing the UL or cUL Certification (such as Canada), respectively.**

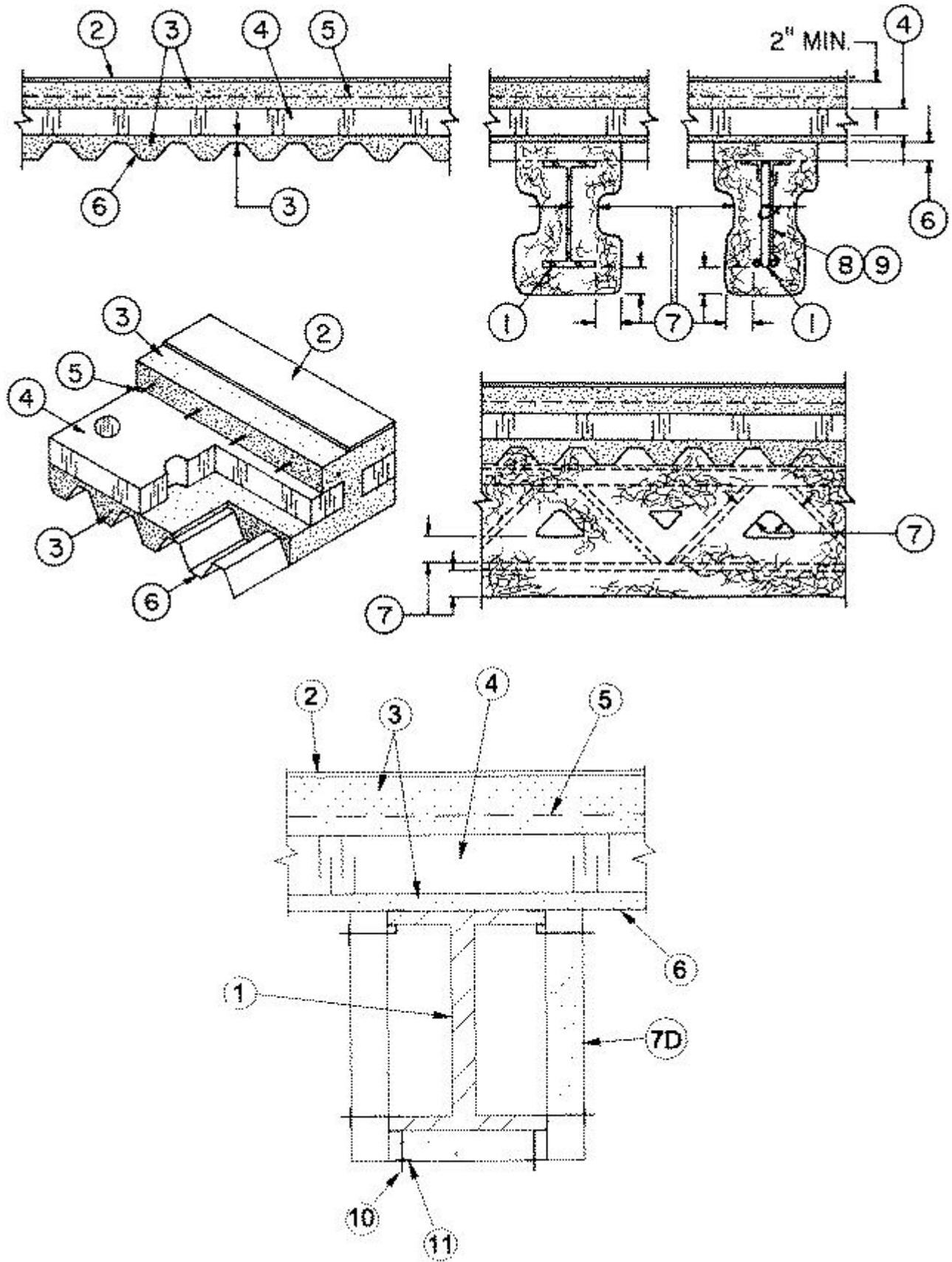

ALTERNATE PROTECTION

1. **Supports** — W6x16, or W8x28 min size steel beams, or Type 10K1 min size steel joists. See Item 7. When steel joists are used, steel bridging angles are required per SJI specifications.

2. **Roof Covering*** — Consisting of hot mopped or cold application materials compatible with insulation(s) described herein which provide Class A, B or C coverings. See Roofing Materials and Systems Directory-Roof Covering Materials (TEVT).

2A. **In lieu of Item 2, roof covering consisting of single-ply Roofing Membrane*** — That is either ballasted, adhered or mechanically attached as permitted under the respective manufacturer's Classification. See Fire Resistance Directory-Roofing Membranes (CHCI).

3. **Insulating Concrete** — Various types of insulating concrete prepared and applied in the thickness indicated below:

A. **Vermiculite Concrete** — 6 cu ft of **Vermiculite Aggregate*** to 94 lbs. of Portland cement and 0.06 to 0.5 lb. of air entraining agent. Min thickness of slurry coat (vermiculite concrete topping thickness as measured from top of steel roof deck to bottom of foamed plastic) shall be as shown in the following table. Min topping thickness above foamed plastic is 2 in. Max topping thickness determined by job site conditions.

Restrained Assembly Rating Hr	Min Steel Roof Deck Depth In.	Min "Slurry" Coat Thkns In.
1-1/2	9/16	5/16
1-1/2	15/16	1/8
2	9/16	1/2
2	15/16	5/16
2	1-5/16	1/8

See **Vermiculite Aggregate** (CJZZ) category for names of Classified companies.

B. **Cellular Concrete — Roof Topping Mixture*** — Foam concentrate mixed with water and Portland cement per manufacturer's specifications. Cast dry density and 28-day compressive strength of min 190 psi as determined in accordance with ASTM C495. A 1/8 in. min thickness slurry coat of cellular concrete, above top plane of steel deck is required. The cellular concrete topping thickness, above 2 in. min thickness foamed plastic, shall be 2 in. min. When foamed plastic is not used, the min thickness of **Roof Topping Mixture*** above the steel deck shall be 2-3/4 in.

AERIX INDUSTRIES — Cast dry density 37 (+ or -) 3.0 pcf.

CELCORE INC — Type Celcore with cast dry density of 31 (+ or - 3.0) pcf or Type Celcore MF with cast dry density of 29 (+ or - 3.0) pcf.

CONCRECEL INTERNATIONAL INC — Cast dry density 38 (+ or -) 3.0 pcf.

ELASTIZELL CORP OF AMERICA — Type II. Mix #1 of cast dry density 39 (+ or -) 3.0 pcf, Mix #2 of cast dry density 40 (+ or -) 3.0 pcf, Mix #3 of cast dry density 47 (+ or -) 3.0 pcf.

SIPLAST INC — Mix #2. Cast dry density of 36 (+ or -) 3.0 pcf.

C. **Perlite Concrete** — 6 cu ft of perlite aggregate* to 94 lb of Portland cement and 1-1/2 pints of air entraining agent. Thickness of perlite concrete topping to be 2 in. min as measured to the top plane of the foamed plastic. Min. thickness between the top of steel deck and the bottom of the foamed plastic shall be 1/8 in.

See **Perlite Aggregate** (CFFX) in Fire Resistance Directory for names of manufacturers.

D. **Cellular Concrete — Roof Topping Mixture*** — Foam Concentrate mixed with water, Portland Cement and UL Classified Vermiculite Aggregate per manufacturer's application instructions. Cast dry density of 33 (+ or -) 3.0 pcf and 28-day compressive strength of min 250 psi as determined in accordance with ASTM C495-86. A 1/8 in. min slurry coat shall be employed below the foamed plastic (Item 4). The cellular concrete topping thickness, above the foamed plastic, shall be 2 in. min. The combined thickness of slurry coat plus concrete topping shall not be less than 2-3/8 in.

AERIX INDUSTRIES — Mix #3.

SIPLAST INC — Mix #3.

E. **Cellular Concrete — Roof Topping Mixture*** — Foam concentrate mixed with water and Portland cement per manufacturer's specifications. Cast dry density and 28-day compressive strength of min 190 psi as determined in accordance with ASTM C495. Min thickness above foamed plastic is 2 in. Min thickness between the top of steel deck and the bottom of foamed plastic shall be 1/8 in. When foamed plastic is not used, the min thickness of Roof Topping Mixture* above the top of the steel deck shall be 2-3/4 in.

CELCORE INC — Type Celcore with cast dry density of 31 (+ or - 3.0) pcf or Type Celcore MF with cast dry density of 29 (+ or - 3.0) pcf.

4. **Foamed Plastic* for Vermiculite concrete applications** — Nominal 24 by 48 by maximum 8 in. thick polystyrene foamed plastic insulation boards having a nominal density of 2.5 pcf max. Each insulation board shall contain holes and/or slots.

See **Foamed Plastic*** (BRYX) category in Building Materials Directory or **Foamed Plastic*** (CCVW) category in Fire Resistance Directory for list of manufacturers.

4A. **Foamed Plastic*** — Nominal 24 by 48 by max 8 in. thick polystyrene foamed plastic insulation boards having a density of 1.0 + 0.1 pcf encapsulated within cellular concrete topping (Item 2). Each insulation board shall contain six nominal 3 in. diameter holes oriented in two rows of three holes each with the holes oriented in two rows of three holes each with the holes spaced 12 in. OC transversely and 16 in. OC longitudinally.

See **Foamed Plastic*** (BRYX) category in Building Materials Directory or **Foamed Plastic*** (CCVW) category in Fire Resistance Directory for list of manufacturers.

4B. **Foamed Plastic*** — (Optional) — For use with cellular concrete. Max thickness 8 in. and containing both hole and slot configuration.

SIPLAST INC

VERMICULITE PRODUCTS INC

4C. **Foamed Plastic*** — Nom 24 by 48 in., 48 by 48 in., 24 by 96 in. or 48 by 96 in. by max 8 in. thick polystyrene foamed plastic insulation boards with holes symmetrically placed having a max density of 2.0 pcf. For use only with cellular concrete roof topping mixture.

STARRFOAM MFG INC

4D. **Foamed Plastic*** — (Optional — For Use With Items 3B or 3E) — Nominal 24 by 48 by max 14 in. thick expanded polystyrene foamed plastic insulation boards having a maximum density of 2.5 +/- 0.1 pcf encapsulated within cellular concrete topping. Each insulation board shall contain eight min 2 in. diameter holes oriented in two rows of four holes each with the holes spaced 12 in. OC transversely and 12 in. OC longitudinally or six min 3 in. diameter holes oriented in two rows of three holes each with the holes spaced 12 in. OC transversely and 16 in. OC longitudinally.

See **Foamed Plastic*** (BRYX) category in Building Materials Directory or **Foamed Plastic*** (CCVW) category in Fire Resistance Directory for list of manufacturers.

5. **Wire Mesh** — (Optional for 1 & 1 1/2 hr. ratings) — No. 19 SWG galv steel wire twisted to form 2 in. hexagons. In addition, straight 16 SWG galv steel woven into mesh and spaced 8 in. apart for stiffness. Mesh installed without attachment perpendicular to supports and overlapped 6 in. at the sides. As an alternate, 4x8-12/14 SWG or 2x2-14/14 SWG welded wire fabric may be used.

5A. **Fiber Reinforcement*** — (Optional, not for use to achieve 2 hr ratings) — For use only with Roof-Topping Mixtures* manufactured by Cellular Concrete LLC. In lieu of Wire Mesh (Item 5), Fiber Reinforcement may be added to roof topping mixtures (Items 3B or 3D). See Fiber Reinforcement (CBXQ) Category for rate that fibers are added to roof topping mixture.

FORTA CORP — Types Econo-Mono, Mighty-Mono, Stucco-Bond, Econo-Net, Cast-Master, Super-Net, Ultra-Net.

6. **Steel Roof Deck** — (Unclassified) — Noncomposite design, vented or nonvented units, 9/16, 15/16 or 1-5/16 in. deep corrugated steel form units, nom 24 to 36 in. wide. When 9/16 in. deep units are used, their loadings shall be limited to produce a 75 percent max bending stresses in the steel, and the Restrained Assembly Rating shall not exceed 1-1/2 H. Supports spaced not over 4 ft, 0 in. OC when 9/16 in. deep, min 28 MSG steel roof deck is used. Supports spaced not over 6 ft, 0 in. OC when 15/16 in. deep, min 26 MSG steel roof deck is used. Supports spaced not over 8 ft, 0 in. OC when 1-5/16 in. deep, min 24 MSG steel roof deck is used. Welded to supports with 3/8 in. puddle welds, through weld washers, spaced 15 in. OC. Adjacent units overlapped one corrugation.

For clear spans not more than 7 ft 8 in. the **Unrestrained Assembly Rating equals the Restrained Assembly Rating.**

Classified Steel Floor and Form Units* — Noncomposite design, 1-5/16 or 1-1/2 in. deep, nom 24 to 36 in. wide, galv corrugated or fluted steel deck. Min gauge for corrugated deck is 24 MSG, min for fluted is 22 MSG. Supports spaced not over 8 ft

0 in. OC. Welded to supports 15 in. OC max. Adjacent corrugated units overlapped one corrugation along each side. Fluted units button-punched or welded together 36 in. OC along sides.

ASC STEEL DECK, DIV OF ASC PROFILES L L C — Types BH-36, BHN-36, BHN-35-1/4, DGB-36, B-36, BN-36, BN-35-1/4, NH-32, NHN-32, DGN-32, N-32, and NN-32. All units may be galvanized or Prime Shield™. Non-cellular decks may be vented designated with a "V" suffix to the product name.

CANAM STEEL CORP — Type P-3606, P-3615, or P-3012.

CANAM STEEL CORP — Types B, UFX, UFXV, UFX-36, UFXV-36.

DECK WEST INC — 36 in. wide Types B-DW or BA-DW.

EPIC METALS CORP — Type Metricform.

KAM INDUSTRIES LTD, DBA CORDECK — Type QL-3 or Sec. 3 with or without up-punched integral hanger tabs.

MARLYN STEEL DECKS INC — Types B, BV, EF, EVF, F, HF, HVF, N, NV.

NEW MILLENNIUM BUILDING SYSTEMS L L C — Types 1.0FD, 1.0FDV, 1.5FD, 1.5FDR, 1.5FDI, 2.0FD, 3.0FD, B, BV, BI, F, N. Types EHD, EHDV, HD, HDV, S, SV, SD, SDV, SDR. Units may be phos/painted or galvanized.

ROOF DECK INC — Types A, B-1, B-2, EHD Multi-Rib or F.

VERCO DECKING INC - A NUCOR CO — Deck types PLB, HSB, PLN3, HSN3, PLN, N, Shallow or Deep VERCOR™, Deep VERCOR VENTLOK, System 80; FORMLOK™ deck types PLB, B, PLN3, N3, PLN, N, PLW2, W2, PLW3, W3. Units may be galvanized, phos./ptd., or mill finish. Deck may be vented or non-vented.

VULCRAFT, DIV OF NUCOR CORP — Types 1.0C, 1.0CSV, 1.3C, 1.3CSV, 1.5C, 2C, 3C, 1.5B, 1.5BI, 1.5PLB, 1.5BSV, 3N, 3NI, 3.0PLN, 3NL-32, 3NI-32, 3PLN-32. Type 3N made from 22MSG or heavier steel may be used on simple or continuous 12 ft 0 in. spans with the total load on these spans limited by the allowable bending stress and/or the deflection criteria of this deck; Types BW, B High Strength, BW High Strength. Nonvented Type BW, vented Type BW, Type BW Slotted Deck.

6A. **Steel Roof Deck** — (For use with Item 7E) — Same as Item 6 with min depth of 1-5/16 in.

7. **Spray-Applied Fire Resistive Materials*** —

A. **Spray-Applied Fire Resistive Materials*** — Applied by mixing with water and spraying in one or more coats to the beam or joist surfaces which are free of oil, dirt or loose scale to the thicknesses shown in the table below. Min average density of 15 pcf with min individual value of 14 pcf, respectively, for Types 300, 300AC, 300ES, 300HS, 300N, 3000, 3000ES and SB. For Types 400AC and 400ES min average and min individual density of 22 and 19 pcf, respectively. For method of density determination, see Design Information Section, Sprayed Material.

Restrained Assembly Rating Hr	Unrestrained Beam Rating Hr	Min Thkns on Beam In. W6x16	Min Thkns * on 10K1 Joist In.
1	1	7/16	15/16
1-1/2 or 2	1-1/2	3/4	1-1/2
2	2	1-1/16	1-13/16

* Spray-Applied Fire Resistive Materials directly applied to joist contours. As an alternate, metal lath or nonmetallic fabric mesh secured to one side of joist to catch overspray when spraying following joist contours. Metal lath to be fully covered with Spray-Applied Fire Resistive Materials but with no min thickness requirements.

BERLIN CO LTD — Types 300, 300ES, 300N, SB, 400AC or 400ES.

GREENTECH THERMAL INSULATION PRODUCTS MFG CO L L C — Types 300, 300AC, or 400AC.

ISOLATEK INTERNATIONAL — Types 300, 300AC, 300ES, 300HS, 300N, SB, 400AC, 400ES, 3000 or 3000ES.

NEWKEM PRODUCTS CORP — Types 300, 300ES, 300N, or SB.

B. (As an alternate to Item A) Spray-Applied Fire Resistive Materials* — Applied by mixing with water and spraying in one or more coats to the beam or joist surfaces which are free of oil, dirt or loose scale to the thicknesses shown in the table below. Min average density of 17.5 pcf with min individual value of 17.0 pcf for Type 280. Min average and min individual density of 17.5 and 16 pcf, respectively, for Type 300TW. Min average and min individual density of 22 and 19 pcf, respectively, for Type 400. For method of density determination, see Design Information Section, Sprayed Material.

Restrained Assembly Rating Hr	Unrestrained Beam Rating Hr	Min Thkns on Beam In. W6x16	Min Thkns * on 10K1 Joist In.
1	1	7/16	15/16 (1-1/16)
1-1/2 or 2	1-1/2	3/4	1-1/2
2	2	1-1/16	1-13/16

* Spray-Applied Fire Resistive Materials directly applied to joist contours. As an alternate, metal lath or nonmetallic fabric mesh secured to one side of joist to catch overspray when spraying following joist contours. Metal lath to be fully covered with Spray-Applied Fire Resistive Materials but with no min thickness requirements. When Type 280 is used for the 1 Hr. Rating, the thickness must be increased from 15/16 in. to 1-1/16 in.

GREENTECH THERMAL INSULATION PRODUCTS MFG CO L L C — Type 400.

ISOLATEK INTERNATIONAL — Types 280, 300TW, 400

NEWKEM PRODUCTS CORP — Type 400.

C. (As an alternate to A and B) Spray-Applied Fire Resistive Materials* — Applied by spraying with water to a final thickness as shown in the table below. Beam and joist surface must be clean and free of dirt, loose scale and oil. When steel joists are used, min thickness of protection material on steel bridging angles shall be same as required on joist, but is not required to exceed 1-3/4 in. For method of density determination, refer to Design Information Section.

Restrained Assembly Rating Hr	Unrestrained Beam Rating Hr	Min Mtl Thkns on 8x28 Beam In.
1	1	1/2
1-1/2 or 2	1-1/2	13/16
2	2	1-1/4

Restrained Assembly Rating Hr	Unrestrained Beam Rating Hr	Min Thkns on 10K1 Joist In.*
1	1	15/16
1-1/2 or 2	1-1/2	1-1/2
2	2	2-5/16

*Protection material directly — applied to joist following joist contours. As an alternate, metal lath (Item 8) or glass fiber mesh (Item 9) secured to one side of joist to catch overspray when spraying following joist contours. Metal lath to be fully covered with protection material but with no minimum thickness requirements.

ISOLATEK INTERNATIONAL — Types D-C/F, HP, II, or Type II HS. Min avg density of 13 pcf with min ind density of 11 pcf for Type D-C/F, II, or II HSf. Min avg and min ind densities of 22 and 19 pcf, respectively, for Type HP. Type EBS or Type X adhesive/surface sealer optional.

7D. **Batts and Blankets*** — Applied in one or multiple layers to the thicknesses shown below. Attached to beam by impaling over wire fasteners (Item 10). Joints spaced 48 in. OC. For multiple layer applications, staggered joints are not required. The area between the top of the beam and the deck crests shall be filled with min 4 pcf mineral wool. The min thickness of batt and blanket material for the various hourly ratings is shown in the following table:

Restrained Assembly Rating Hr	Unrestrained Beam Rating Hr	Min Thkns on W6x16 Beam In.
1	1	1**
1-1/2	1-1/2	1-1/2
2	1	2
2	2	2-1/2

** For the 1 hr rating, the area between the top of the beam and the deck crests do not need to be filled with 4 pcf mineral wool if the protection thickness is increased to 1-1/2 in.

ISOLATEK INTERNATIONAL — Type CB.

7E. **Spray-Applied Fire Resistive Materials*** — Applied by mixing with water and spraying or troweling in one or more coats to a final thickness as shown in the table below, to steel surfaces which must be clean and free of dirt, loose scale and oil. Min avg density of 44 pcf with min ind value of 40 pcf for Type M-II. Min avg density of 44 pcf with min ind value of 42 pcf for Type TG. For method of density determination, see Design Information Section.

Restrained Assembly Rating Hr	Unrestrained Beam Rating Hr	Min Mtl Thkns on 8x28 Beam In.	Min Thkns on 10K1 Joist In.*
1	1	9/16	1
1-1/2 or 2	1-1/2	13/16	1-1/2
2	2	1-1/4	2-5/16

* Protection material directly applied to joist following joist contours. As an alternate, metal lath (Item 8) or glass fiber mesh (Item 9) secured to one side of joist to catch overspray when spraying following joist contours. Metal lath to be fully covered with protection material but with no minimum thickness requirements.

GREENTECH THERMAL INSULATION PRODUCTS MFG CO L L C — Types M-II or TG. Types M-II and TG investigated for exterior use.

ISOLATEK INTERNATIONAL — Types M-II or TG. Types M-II and TG investigated for exterior use.

NEWKEM PRODUCTS CORP — Types M-II or TG. Types M-II and TG investigated for exterior use.

8. **Metal Lath** — (Optional) — 3/8 in. Diamond mesh, expanded steel weighing, 2.5 lb/sq yd. Lath attached to each joist web member with No. 16 SWG steel tie wire.

9. **Glass Fiber Mesh** — As an alternate to metal lath (Item 8) min. 3/32 in. square mesh, coated fiberglass scrim fabric, weighing a min. of 1.9 oz/sq yd. shall be attached to one side of each joist web member. The method of attachment must be sufficient to hold the mesh and

fire protection material during application and curing of the material. An acceptable method of attaching the mesh is by embedding the mesh in min. 1/4 in. long beads of hot melted glue. The beads of glue shall be spaced min. 12 in. OC along the top chord of the bar joists. Another method of attachment is the use of 1-1/4 in. long, 1/2 in. wide hairpin clips formed from 0.064 in. diameter steel wire, alternating from top to bottom of the joist web member.

10. **Fasteners** — For use with Item 7D. Cafclip (No. 11 SWG) fasteners of sufficient length to accommodate the batt thickness with min 1/4 in. spike length. Excess spike length may be cut or bent. Fitted onto beam flange edges and spaced not greater than 24 in. OC and 3 in. from end of batts. Refer to Design No. D915 for illustration of Cafclip fastener .

11. **Clinch Shields** — For use with Item 10. 1-1/2 in. diam or 1-1/2 in. square formed of 26 MSG steel. One clinch shield is required per impaling spike.

*** Indicates such products shall bear the UL or cUL Certification Mark for jurisdictions employing the UL or cUL Certification (such as Canada), respectively.**

Last Updated on 2019-02-11

The appearance of a company's name or product in this database does not in itself assure that products so identified have been manufactured under UL's Follow-Up Service. Only those products bearing the UL Mark should be considered to be Certified and covered under UL's Follow-Up Service. Always look for the Mark on the product.

UL permits the reproduction of the material contained in the Online Certification Directory subject to the following conditions: 1. The Guide Information, Assemblies, Constructions, Designs, Systems, and/or Certifications (files) must be presented in their entirety and in a non-misleading manner, without any manipulation of the data (or drawings). 2. The statement "Reprinted from the Online Certifications Directory with permission from UL" must appear adjacent to the extracted material. In addition, the reprinted material must include a copyright notice in the following format: "© 2019 UL LLC"